

C-4001 **CHAMPION INDUSTRIAL SPARK PLUG**

This plug is a newly designed High-Performance spark plug. The improved ceramic material allows high voltage strength for future application.

Tenneco's new M14 J-Gap series with Double Iridium electrodes starts with new nomenclature. C-4001 stands for double Iridium M14 J-Gap high performance spark plugs developed for usage in natural gas engines in stationary and transient applications.



C-4001

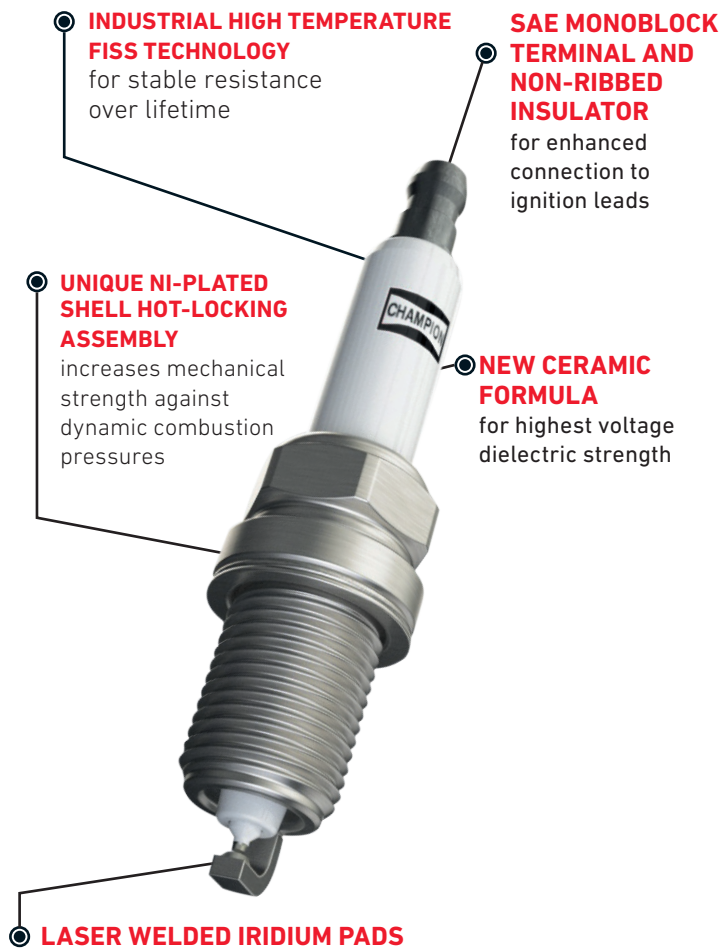

Electrode Gap, Nom.

0,2mm **0,25mm** **0,3mm**

Electrode Resistance

2 kΩ **3 - 12 kΩ** **16 kΩ**

Federal-Mogul Ignition GmbH
Bürgermeister-Schmidt-Str. 17
51399 Burscheid, Germany
<https://ignition.tenneco.com>

© 2020 Tenneco Inc. All rights reserved. All trademarks are owned by Tenneco Inc. or one of its subsidiaries, in one or more countries. C-4001 Rev 11/2021

Basic Technical Data

Properties	C-4001
Suppressor Resistor	3 - 12 kΩ
Hex	16mm
Thread	M14x1,25
Thread length	19mm
Precious metals	Iridium/Iridium
Electrode gap	nom. 0.25
Tightening Torque (Cast iron)	30-40Nm

Dimensions

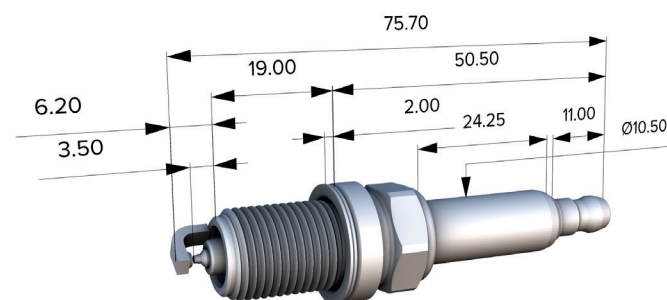

Target Applications

- stationary Biogas or Natural Gas Engines

Engines

- Scania, MAN 2G, Cummins, Perkins

Cross References

- Denso GK 3-1, GK3-5